

Paper ID ICLASS06-243

Flow and Spray Characteristics of a High Frequency Low Cost Fuel Injection System for Small Engines.

J. Allen<sup>1\*</sup>, P. Ravenhill<sup>1</sup>

<sup>1</sup> Scion-Sprays Ltd, Hethel Engineering Centre, Norwich, NR14 8FB, UK.

ABSTRACT

This paper presents and discusses experimental results from a novel high frequency low cost fuel injection system, capable of operating at frequencies over 1kHz and delivering over 40 individual pulses per engine cycle.

**Keywords:** Fuel Injection, Small engine, Pulse count,

1. INTRODUCTION

New emission legislations on small engines are coming into force world wide. This will affect all small engines under 19kW in power, such as hand-held tools, stationary generators, lawnmowers and off-road vehicles. Illustrated in Fig. 1 is an example of the emission reduction requirements for these engines over the coming years.

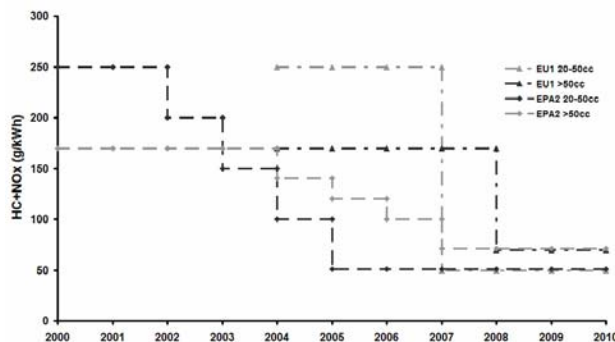

Figure 1. Emission Legislation Levels for Small Engines [Ref.1]

Globally there is production of many tens of millions of engines per year that will fall into this category and they must all meet these new emission standards now or in the very near future.

In many applications manufacturers have already switched from 2-stroke to 4-stroke engines to achieve cleaner emissions, and manufacturers of 4-stroke engines expecting to add catalytic converters to them in the near future.

However, this market is extremely cost sensitive with many of the engines being air-cooled single cylinder small capacity units using simple carburettors. It is therefore vital that any technology added to the engines must achieve maximum emission benefit for the absolute minimum on-cost and minimum parasitic power consumption.

A limited number of readily available options are available to meet these emission standards, they include continued use of carburettors with the addition of a 2-way catalyst, or improved fuel quantity control through the use of more sophisticated carburettors or

electronic fuel injection systems either with or without catalysts.

Whilst it is generally accepted that the electronic fuel injection technology is the best way to achieve accurate fuel flow control under all conditions (as demonstrated by its use in the automotive market) it is also recognised that a typical automotive fuel injection system, including injector, pump, pressure regulator, sensors and a substantial electronic controller, is too complex and expensive for application into this market.

Therefore this paper presents a novel fuel injection system that is specifically designed for this small engine market and will allow accurate fuel control without the need for fuel pumps, pressure regulator or complex electronics.

2. FUEL INJECTOR CONCEPTS

In order to reduce the number of system components to as smaller number as possible and hence reduce the system cost to a minimum it is necessary to integrate as many functions as possible into single units.

2.1 Pulse Width Modulated:

The conventional approach used by all automotive fuel injection systems to control the quantity of fuel injected per engine cycle is the Pulse Width Modulation (PWM) concept (as described in Figs.2 and 3.) With this process the fuel quantity delivered is controlled by a known fluid flow rate through a fixed orifice over an accurately controlled time period, as shown schematically in figure 2. To achieve this accurately controlled fluid flow rate it is necessary to have a precisely controlled pressure difference across the orifice, which is usually achieved by the combination of a high pressure fuel pump and a pressure regulator with a pressure compensation feed connected to the intake manifold of the engine in the region of the fuel injector. Along with these pressure system components it is also necessary to have an on/off flow control valve that will open and close very rapidly with high repeatability matched to a very sophisticated electronic controller allowing for precisely controlled opening periods of the flow valve.

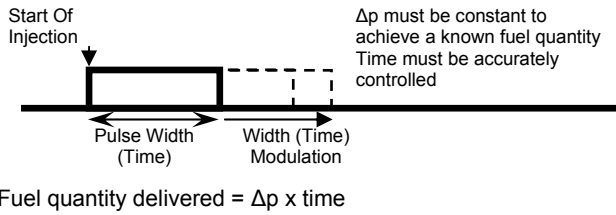

**Figure 2.** Schematic of a PWM injection process for a single engine cycle.

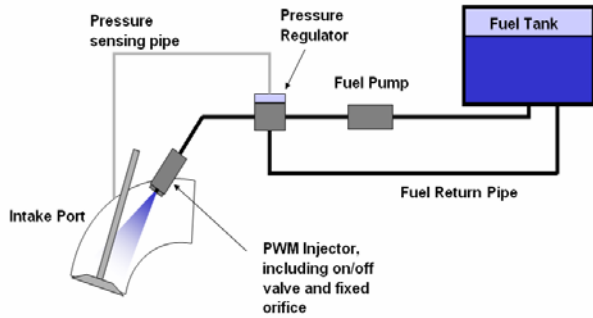
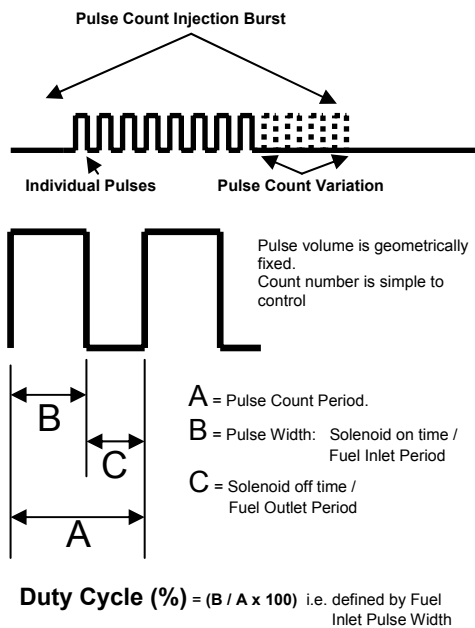

**Figure 3.** Illustration of components in a PWM fuel system.

**2.2 Pulse Count Injection:**

As an alternative to Pulse Width Modulation the novel concept of Pulse Count Injection (PCI) [Ref. 2] has been developed to deliver the precisely controlled fuel quantity required per engine cycle.

PCI uses a small geometrically fixed volume to repeatedly inject a known amount of fuel into the engine intake manifold.

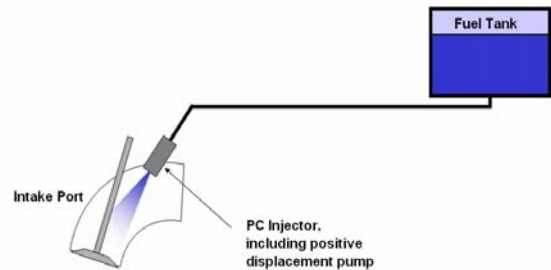

**Figure 4.** Schematic of a PCI injection process for a single cylinder cycle.

The number of pulses of injected fuel determines the amount of fuel delivered to the engine which in turn is governed by the load, as shown schematically in Fig 4.

In order to achieve this fuel flow control process the injector is constructed as a simple positive displacement pump with a solenoid driven piston and cylinder working as the fixed volume displacement unit and two one-way check valves to ensure the correct flow path of the fluid into and out of the injector, shown in the sectioned drawing in figure 6. In this arrangement the single injector acts both as the pumping unit and the flow metering unit together. Also because the flow volume delivered by each pulse is a fixed geometric volume the process is independent of differential pressure across the injector, making it very insensitive to pressure fluctuations in the intake manifold.

The PCI system (shown in Fig.5) therefore contains significantly fewer parts than the PWM system but still delivers an accurately controlled volume of fuel to the engine each cycle.



**Figure 5.** Illustration of components in a PCI fuel system.

Refinement of fuel quantity control becomes therefore a matter of optimising: the size of the geometrically fixed volume, the frequency of operation of the PCI injector and the number of pulses required per engine cycle.

A typical fixed volume is less than 0.5µl, with a typical operational frequency of greater than 1kHz. This typical range is suitable for many engine capacities in the small engine market.

The following work, details the early test work on this novel type of fuel injector proving the concepts functionality.

**3. FIRST HARDWARE CONCEPTS**

The first prototype versions of the PCI concept have been constructed from “off the shelf components”.

For example the solenoid and armature assembly are sourced from a standard Gasoline Direct Injector which has the ability to be stripped down. This enabled a special valve head assembly to be fitted below it. See schematic below.

Once the prototype PCI had been built it was tested both on the spray bench and the Engine rig.

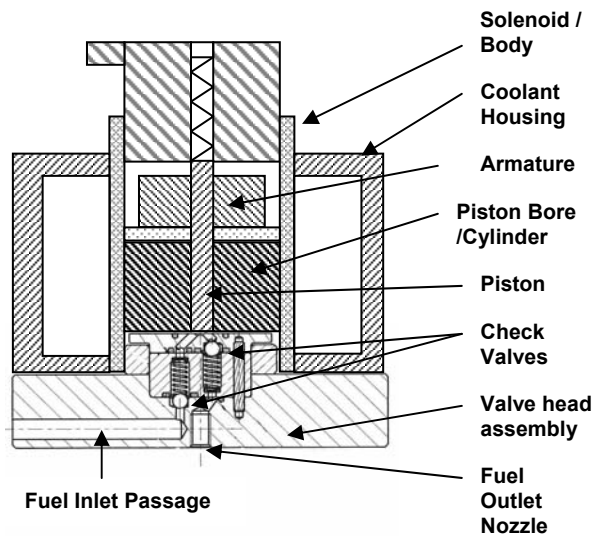

**Figure 6.** A sectioned drawing of the prototype Pulse Count injector.

#### 4. RIG TESTING

The Injector Spray Rig (shown in Figure 7) consisted of the following Parts: Fuel tank, x y traverse and stand, Pulse Count Injector, Coolant system, catch tank, mass-balance, Pulse Generator and Transistor Amplifier.

A High speed LaVision Flowmaster CCD camera was added to the rig to capture spray images when required (as seen in the bottom right of the photograph.) using a flash to back-light the image.

The fuel used was pump Gasoline (95RON.)

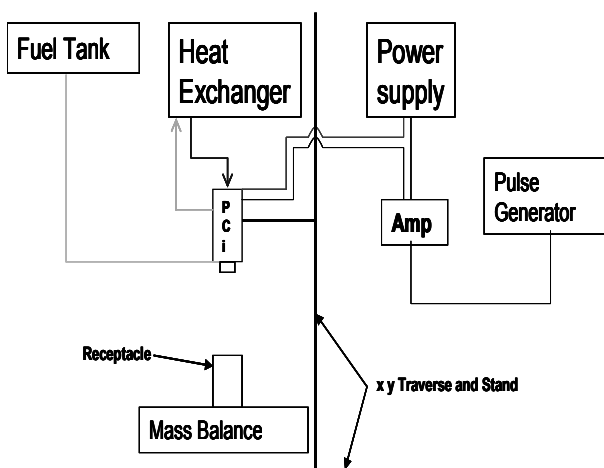

**Figure 7.** Schematic of the PCI spray rig.

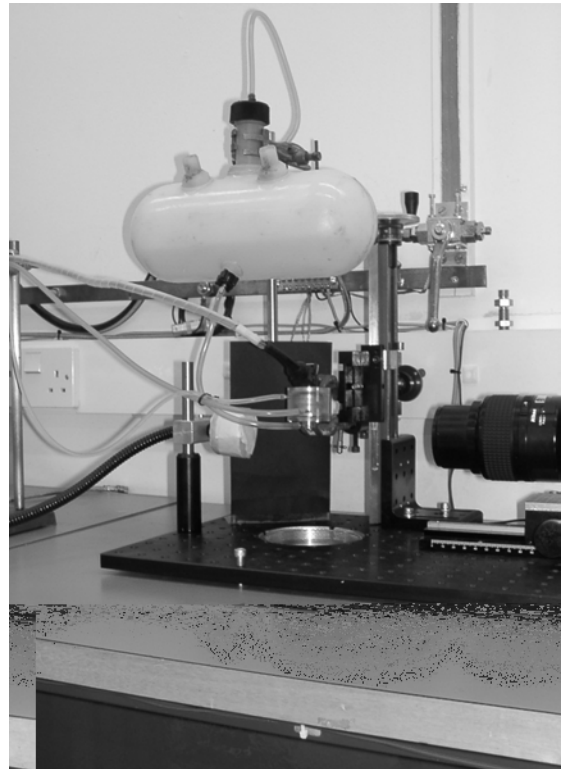

**Figure 8.** Photograph of the PCI spray rig with camera and flash light.

To drive the Pulse Count Injector a standard NPN transistor (TP 121) was used as the signal amplifier, switching the solenoid to earth.

The power generator used was a standard RS Laboratory unit rated to 30Amps. The voltage for all these tests was held at 12V.

The signal generator used was a DEI PDG-2510. This has a burst function enabling a set number of pulses to be fired at set intervals. The interval function was set to 2Hz and the number of pulse counts to 100.

Initial testing of the PCI used 'Mass of Fuel per Pulse' as a performance marker hence the PCI could be closely monitored through out all of the experiments.

The variables in each of the experiments were:

- Frequency
- Duty Cycle (Based on the solenoid on time to off time.)

Shown in graphs 1 and 2 are the results of the Initial prototype PCI running from 100Hz to 1kHz. Graph 1 shows the mass/pulse performance of the PCI for each frequency with the Duty cycle set to give maximum fuel delivery.

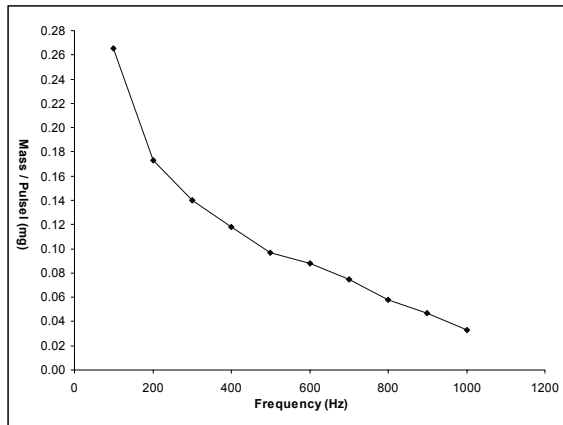

**Graph1.** Maximum Mass / Pulse of fuel vs Frequency for prototype PCI.

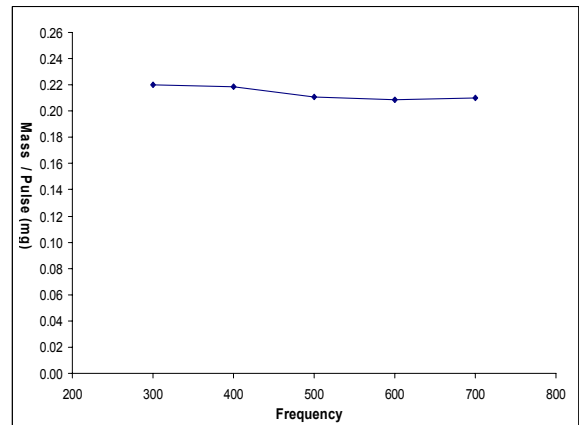

**Graph 3.** Relationship between Maximum Mass / Pulse vs. Frequency for the modified PCI.

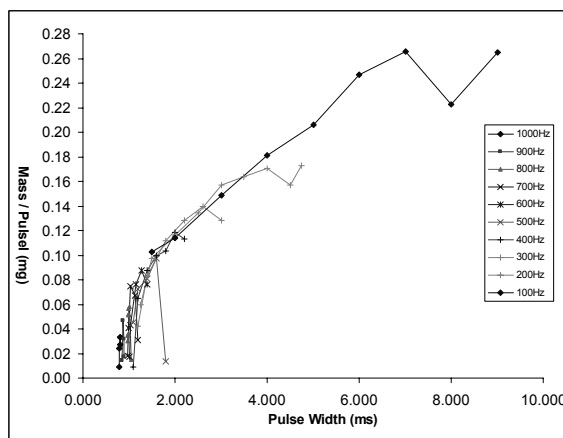

**Graph 2.** Mass / Pulse vs. Inlet Valve Pulse Width for the Prototype PCI.

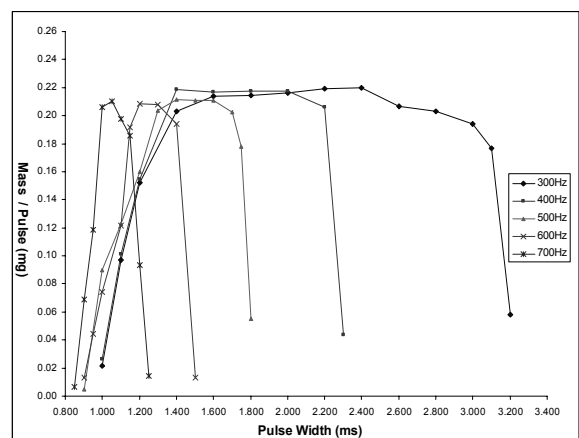

**Graph 4.** Mass / Pulse vs. Inlet Pulse Width for the modified PCI.

Graph 2 shows the full data set with the inlet pulse width on the horizontal axis as the duty cycle was varied at each set frequency.

It can be seen that the performance of the Inlet Check valve decreases with reducing pulse width (decreasing duty cycle) even at the lower frequencies, which indicated that the performance of the intake stroke and the intake check valve was a limiting factor to the performance of the whole PCI unit.

The prototype PCI injector was modified to optimise the inlet check valve performance by reducing its spring rate (lowered from 1.73N/mm to 0.56N/mm.) in order to allow greater lift of the check ball from its seat during the inlet stroke, also the piston displacement was reduced slightly to 140µm to lower the volume of fuel drawn into the injector on each pulse.

The set of test results shown below in Graphs 3, 4 & 5, are for the PCI in this new running condition, showing a stable fuel delivery characteristic independent of frequency from 300Hz to 700Hz. Graph 3 shows the fuel delivery in mg of the PCI across the frequency range, whilst Graph 4 demonstrates the overall performance of the injector is not now solely dependant on the inlet check valve performance.

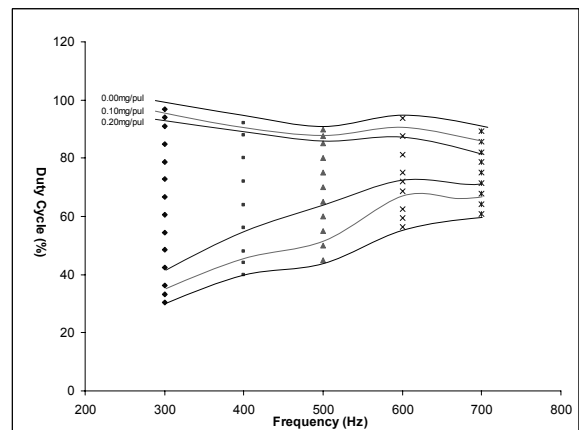

**Graph 5.** Duty Cycle vs. Frequency for the modified PCI, with contour lines of common Mass of fuel / Pulse delivered.

Graph 5 shows a contour map of the injectors overall spray performance it was generated by interpolating lines of common mass of fuel / pulse. The upper set of contour lines are a function of the performance boundary of the outlet valve whilst the lower set of contour lines are a function of the performance boundary of the inlet valves. The narrowing band in the centre represents a consistent flow area setting showing a large tolerance to varying

Duty Cycle settings at low frequencies and a narrowing of that tolerance band at the higher frequencies.

### 5. SPRAY RIG PHOTOGRAPHY

The following photographs were taken on the spray bench using the La Vision Flowmaster CCD camera mentioned previously. They show a sequence from start to end of a single pulse of fuel from a prototype PCI running at 500Hz, the volume of fuel per pulse in this running condition = 0.46µltrs, the reason for this increase over previous running conditions is that the piston stroke was increased from 140um to 220um. Photograph A shows the initial slug of fuel bursting from the 150um orifice, B shows the issuing jet still under pressure, C shows the jets decay as the outlet valve closes and D shows the remnants of the jet and the emergence of another pulse of fuel.

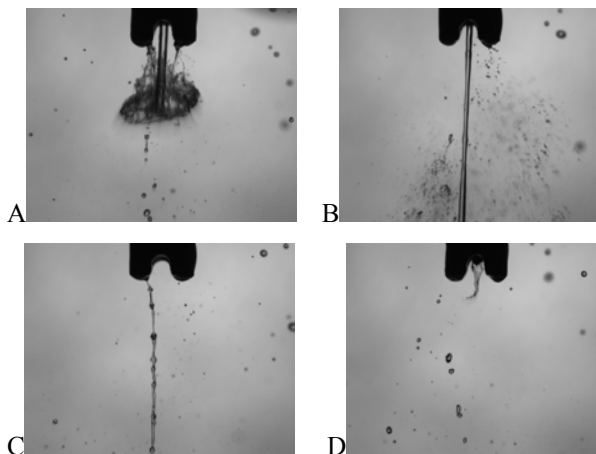

**Figure 9.** A = 0.5ms delay from start of Injection pulse, B = 1.0ms, C = 1.5ms, D = 2.0ms.

### 6. ENGINE TESTING

**Table 1.** Describes how a PCI running at 1kHz with a delivery volume per pulse of 0.314µltrs can run an 80cc engine under different load conditions. The cycle time at an engine speed of 3000rpm is 0.04sec therefore giving a maximum of 40 pulses / cycle.

Load	PCI Freq (Hz)	Required Fuel Vol/ cyl (µltrs)	Required No. of pulses
IDLE	1000	3	10
25%	1000	4	13
50%	1000	5	16
75%	1000	6	19
100%	1000	7	22

At full load it will be seen that the injector only needs to fire 22 times to provide enough fuel/cycle.

The modified PCI was put on the 80cc Engine and run at 500Hz. Its delivery volume was measured on the test rig as 0.20mg/pulse = 8.7ml/min.

Although these conditions did not fit the original target it was still possible to run the engine with the PCI.

The PCI was run in this configuration for a total of 25hrs on the engine.

### 7. ENGINE EMISSION TESTING

Emission work has been performed on the 80cc engine using a PCI.

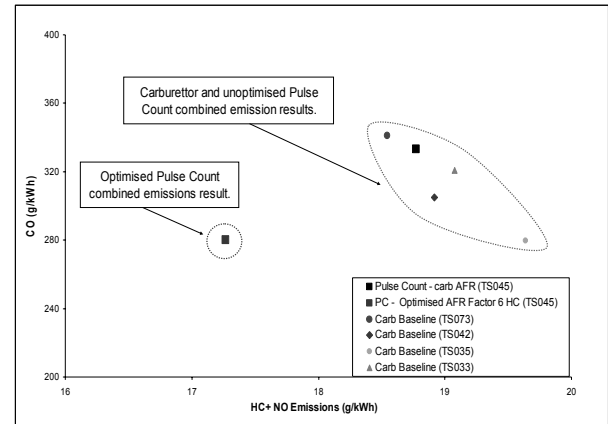

**Graph 6.** 80cc Engine Emission Test Results with comparison between the engine with a carburettor and then with a PCI.

Graph 6 shows the result of optimising the PCI to achieve the best combined emission result.

Optimisation comprises of timing the injection event during the cycle and controlling the Air/Fuel Ratio at each specific emission test point.

As can be seen in Graph 6 a clear decrease in emissions can be achieved.

Further reductions in emissions can be achieved by optimising the fuel entry position and its atomisation in the engine,

### 8. NEW AND FUTURE WORK

Further work using the Gen'0' PCI's will be looking specifically into check valve development and overall PCI durability.

A new PCI injector is currently being developed using bespoke parts that have been optimised for this particular application. The areas under close scrutiny are the Solenoid, Piston, Check valves and Heat Management.

Atomisation will also become an increasingly critical area of investigation. The small amount of power available from the targeted small engines has required a different approach to achieving the fuel atomisation levels required for effective fuel air mixing and therefore better engine exhaust emissions.

Methods could include the introduction of Sonic Air blast or Air shear or even the introduction of Electrostatics.

## 9. CONCLUSIONS

- The Pulse Count Injector has been able to pump and spray fuel at a pulse frequency of 1kHz.
- Pulse Count Injection has proven itself on the spray bench and on the engine as a viable alternative to either standard automotive style fuel injection or carburettors.
- Improvements in emissions by Pulse Count Injection fuel control alone has shown a lowering of emissions by 10% compared to the standard carburetted engine.
- The simplicity of design, control and packaging of the Pulse Count Injection system lends itself to its use on small engines in this very cost sensitive market

## 10. REFERENCES

- [1] European Directives: 1997/68/EC  
2002/88/EC
- [2] UK Patent : GB0516235.9

